

ZONE	REV.	DESCRIPTION	DATE	APPROVED
A		PROTOTYPE	20/03/2014	GREGORY
B		CHANGE TABLE ,ADD FILTER 2 PIN 110V	12/10/2014	GREGORY
C		ADDED HOLES THREAD IN THE CUT OUT	11/17/2014	OLEG

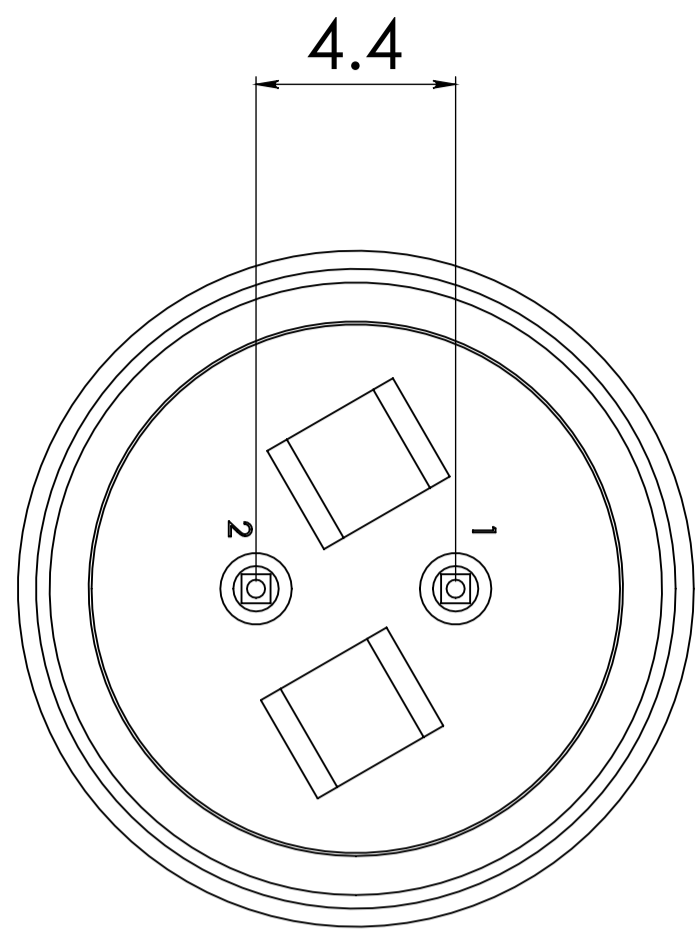

**FILTER 2 PIN
FILTER 2 PIN 110V**

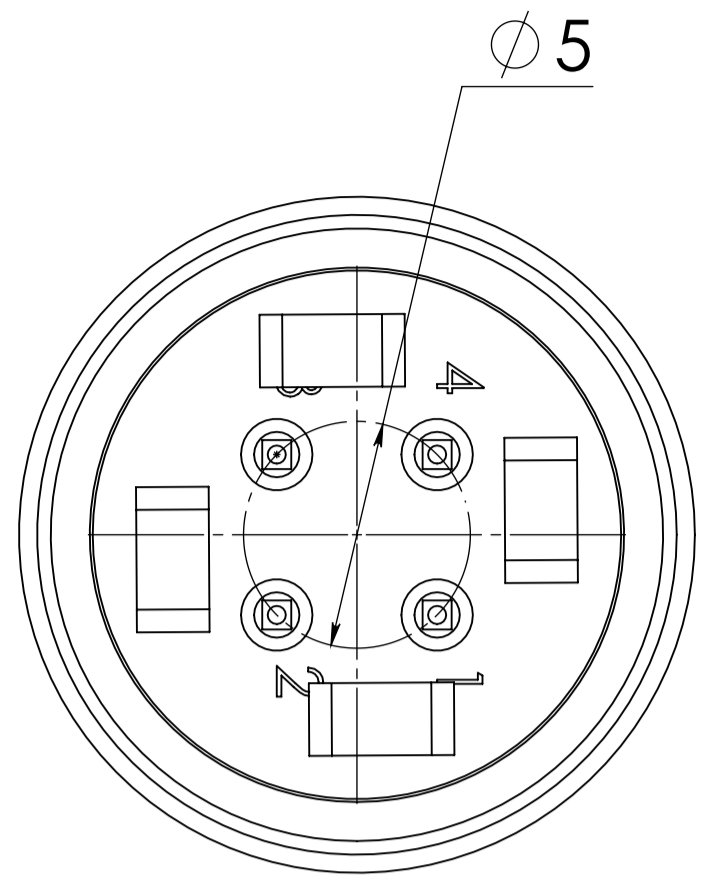

FILTER 4 PIN

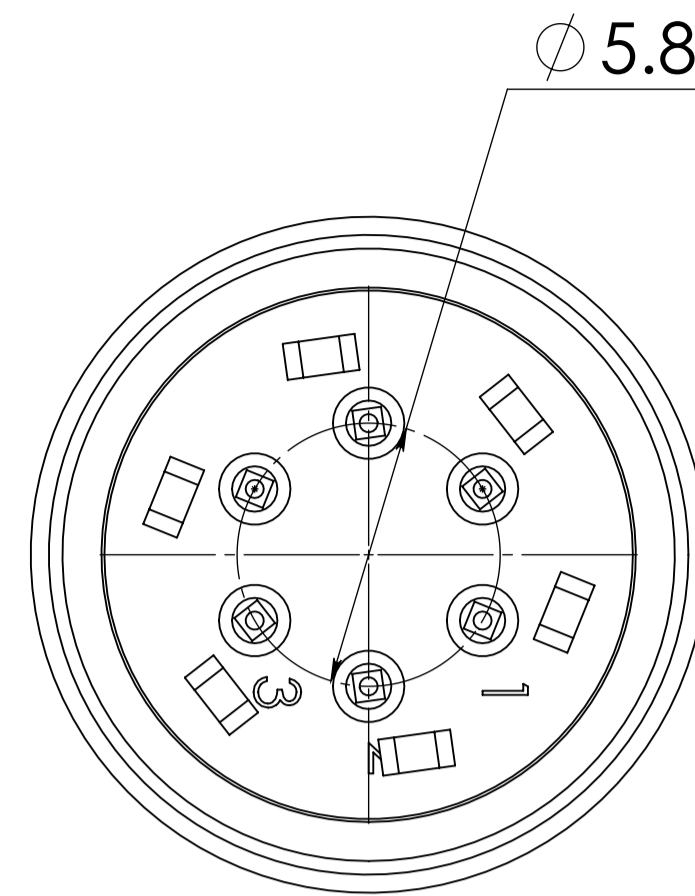

FILTER 6 PIN

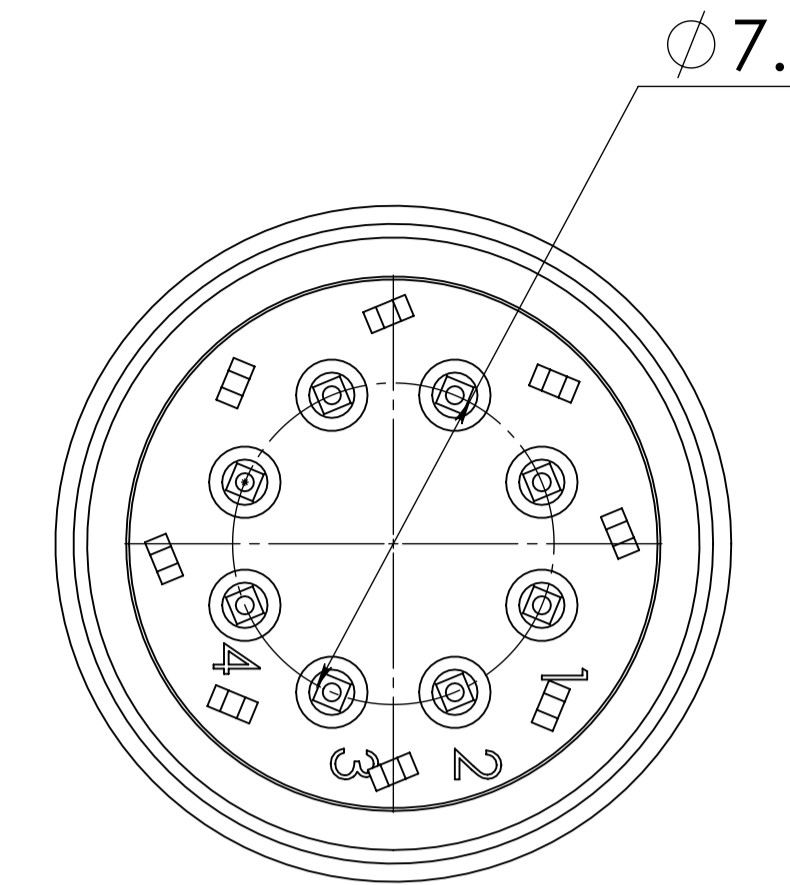

FILTER 8 PIN

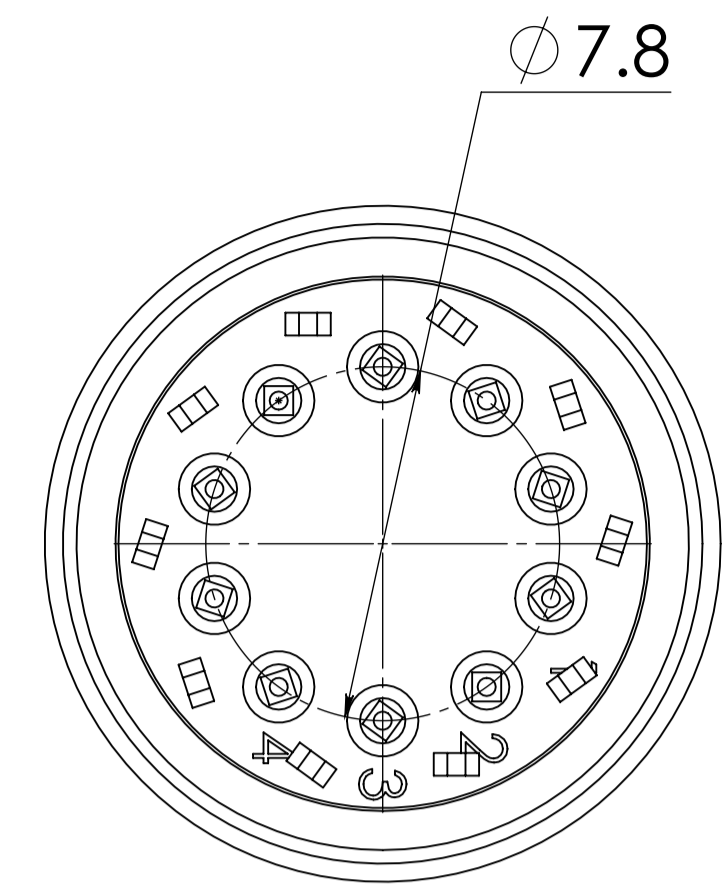

FILTER 10 PIN

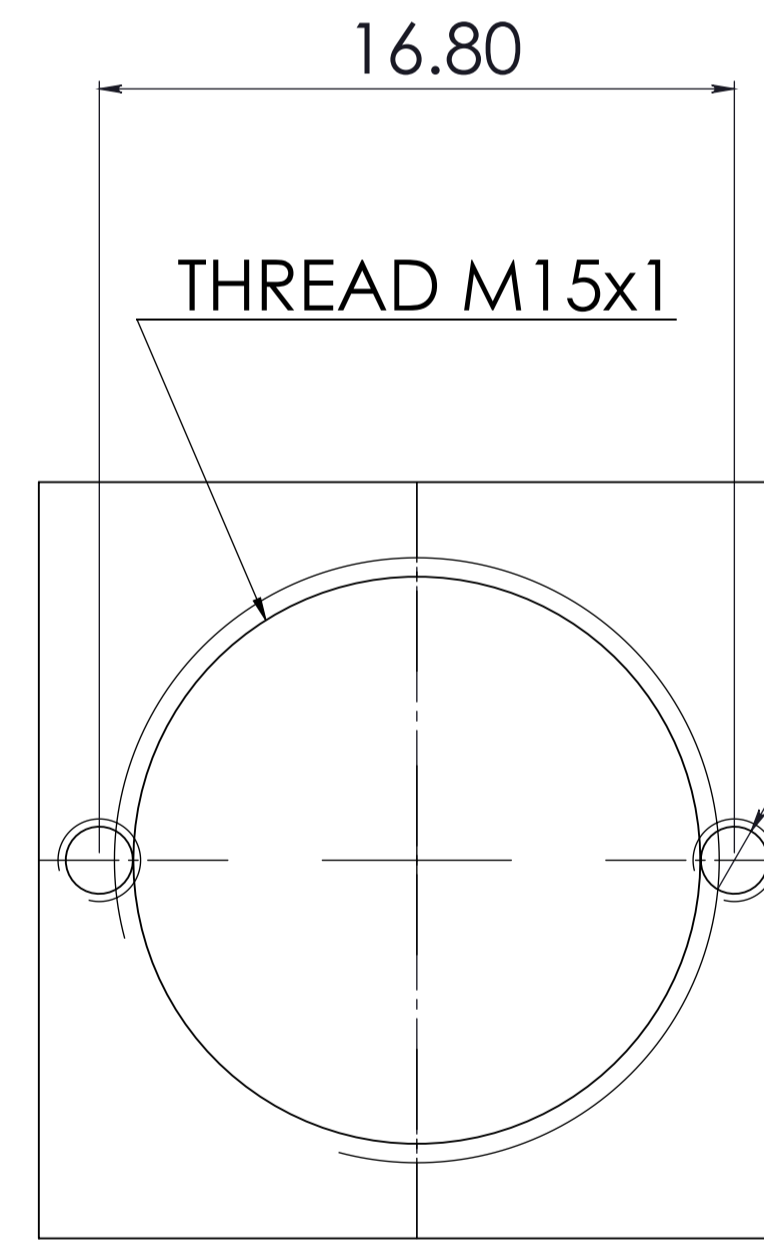
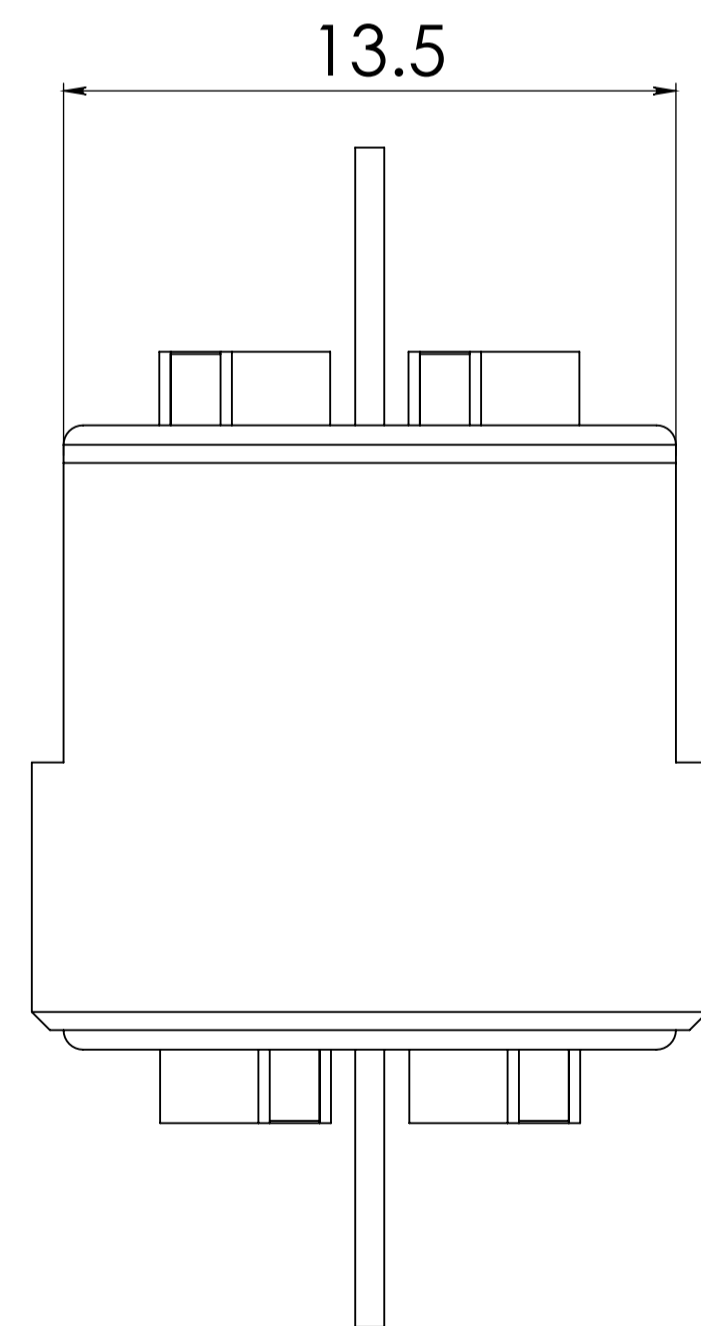
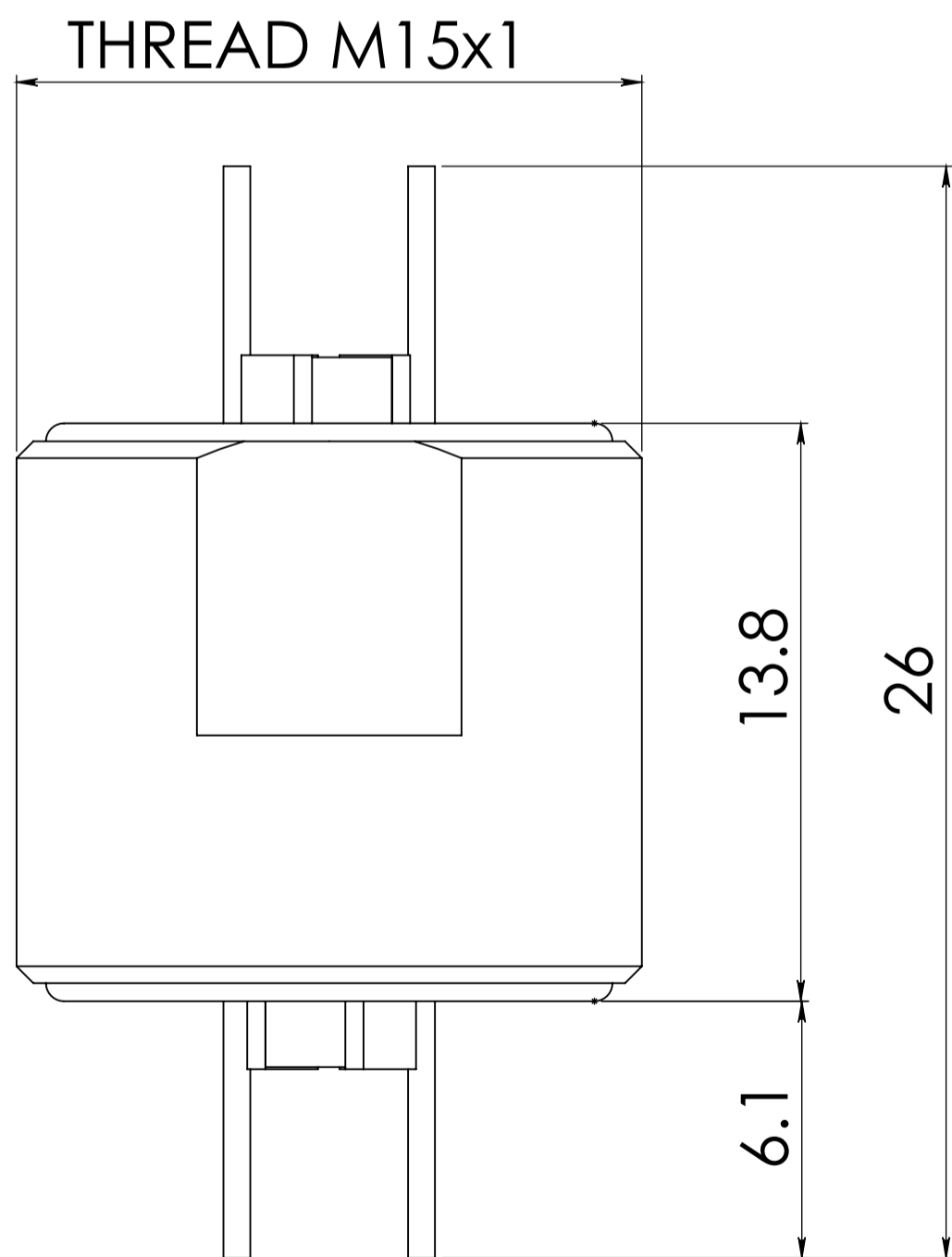

CUTOUT

**THREAD
2-56 UNC THRU ALL (2x)**

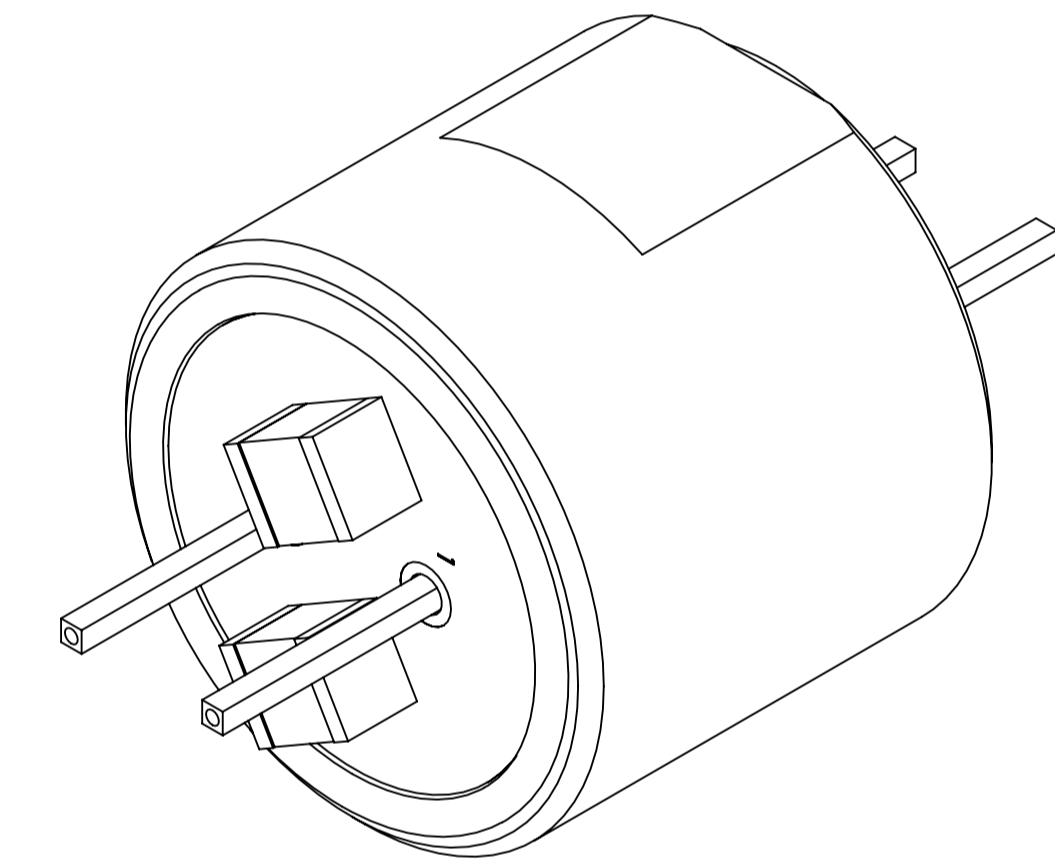

DESCRIPTION	P/N
POWER FILTER 2 PIN	IN08-SA-15
POWER FILTER 4 PIN	IN08-SA-16
POWER FILTER 6 PIN	IN08-SA-18
POWER FILTER 8 PIN	IN08-SA-19
POWER FILTER 10 PIN	IN08-SA-20
POWER FILTER 2 PIN 110V	IN08-SA-24

1. MATERIAL :
OUTER SHELL-ALUMINUM, COATING-CHROMAT PASSIVATION.
2. CONTACT : COOPER ALLOY, PLATING : SELECTIVE GOLD PLATED
3. INSULATOR : FR4.

TOLERANCES UNLESS OTHERWISE STATED		MATERIAL:	FINISH:	MASS:
LINEAR ±0.2	HOLES DIA +	SEE NOTE	SEE NONE	1.23
ANGULAR ±	MASH, SURF'S N7			
NAME	SIGNATURE	DATE	TITLE	
DRAWN ELEHA	E.L.		SEE TABLE	
DESIGN GREGORY	G.L.			
CHECK I.K.				
APPV'D I.K.				
PROJECT		PART. NO.	VERSION	
		SEE TABLE		
<small>THIS DOCUMENT CONTAINS PROPRIETARY INFORMATION AND SHALL NOT BE REPRODUCED OR USED FOR ANY PURPOSE WITHOUT THE PRIOR WRITTEN PERMISSION OF A.I.L. DO NOT MANUALLY UPDATE. DO NOT SCALE DRAWING.</small>		 Engineering Development & Consulting	DWG. NO. IN08-DS-15-C	REV. C SHEET 1/1
SIZE A3	FIRST ANGLE PROJECTION	DIM UNIT	SCALE 6:1	
CONTACT INFO: Tel: +972(0)8-9400002; Fax:972(0)3-7256610 Mobile: +972(0)50-651666; E-mail: office@intaltech.com				

P:\Projects\Projects in R&D Status\Intal Tech\IN08 VARIOUS\O\IN08\IN08-DS-15-C 11/17/2014